

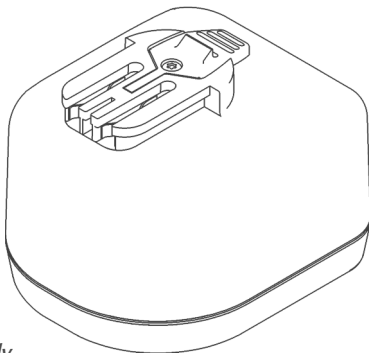

BRASSLER USA[®]
SURGICAL POWER & ACCESSORIES

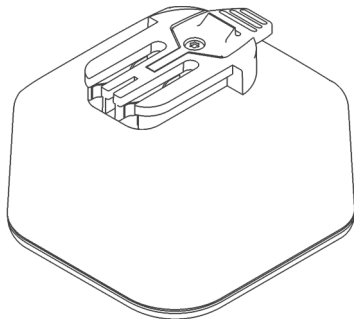

Rx Only

BSP MAX[™] II

BATTERY PACKS

**9.6V BATTERY PACK
PM-X00-710**

**12V BATTERY PACK
PM-X00-715**

Instructions for Use

Table of Contents

Introduction	<i>Page 4</i>
Intended Use	<i>Page 4</i>
Warnings	<i>Page 5</i>
Cautions	<i>Page 5</i>
Notes	<i>Page 5</i>
Explanation of Symbols	<i>Page 6</i>
Features	<i>Page 6</i>
Battery Pack - Installation & Removal	<i>Page 7</i>
Troubleshooting	<i>Page 8</i>
Cleaning Recommendations	<i>Page 9</i>
Sterilization Recommendations	<i>Page 10</i>
Specifications	<i>Page 12</i>
Warranty	<i>Page 12</i>
Return Goods Policy	<i>Page 13</i>
Product Disposal	<i>Page 14</i>
Product Ordering Information	<i>Page 14</i>

Introduction

Thank you for choosing Brasseler USA® Surgical Power & Accessories as supplier of your large bone power system.

The information and procedures described in this manual are intended to assist medical professionals in the safe and effective use, care, cleaning, sterilization and long-term maintenance of BSPMAX™ II Large Bone Power System.

Intended Use

The BSPMAX™ II 9.6V Battery Pack PM-X00-710 and 12V Battery Pack PM-X00-715 are intended for use with the BSPMAX™ II handpieces only. Charge these battery packs on the BSPMAX™ II 4-Bay Power Unit PM-X00-520 (110 volt) unit or PM-X00-522 (230 volt) unit configured with the Standard Battery Pack Charging Bay PM-X00-731 only.

Warnings

- Only trained and experienced medical professionals should use this equipment. Failure to comply with the BSPMAX™ II Instructions for Use may result in patient and/or medical staff injury.
- DANGER - Explosion Hazard. DO NOT use in atmospheres containing flammable gasses (anesthetics, etc) with concentrations within explosive limits.
- Use of eye protection is required while operating equipment.
- Inspect battery pack case for cracks prior to use. Do not use a damaged battery pack.
- DO NOT expose battery packs to fire or incineration.
- DO NOT allow battery pack contacts to contact metal objects. Contact with metal objects may result in electrical shock or a burn injury to the user.
- Under certain classifications of risk, the World Health Organization (WHO), or local regulatory authorities recommend special CJD (Creutzfeldt-Jakob Disease) inactivation processing procedures. Consult WHO and local regulations for further information.

Cautions

- Battery packs contain nickel cadmium, which must be recycled or disposed of properly. See product disposal instructions.
- DO NOT store battery packs on handpieces. Batteries will discharge if they are connected to the handpiece even though the handpiece is not running and will cause irreparable damage to the battery cells.
- DO NOT use battery packs while warm. Allow adequate time for cooling prior to use. Cool by exposure to room temperature.
- REMOVE battery packs from charging bays when 4-Bay Power Unit is off to avoid battery discharge and/or damage.

Notes

- Recharge battery packs before each use to ensure maximum running time.
- The charge cycle takes approximately 5-60 minutes.
- The expected run time of a fully charged battery pack is approximately 3-15 minutes depending on surgical demand and battery type.
- Only use battery packs that have been charged within 48 hours.
- Store battery packs on an activated charger where they will maintain a full charge, until they are sterilized.

Explanation of Symbols



Batch code.



Do not discard. Dispose of product or recycle in accordance with local laws and regulations.



Catalog number.



Manufacturer.



Caution.



Nickel-Cadmium rechargeable batteries.

Ni-Cd



Date of manufacture.



Temperature limit.

Features

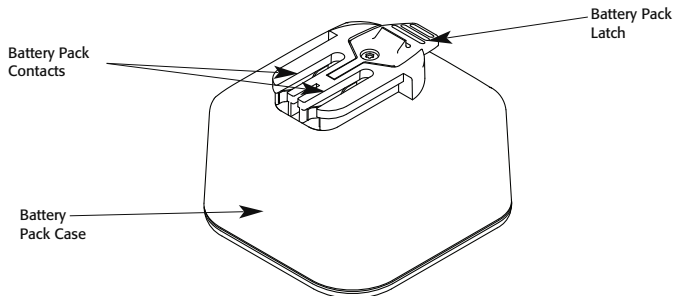

- **Battery Pack Case** – Housing for rechargeable sterilizable batteries that provide power to the handpiece.
- **Battery Contacts** – Conducts charge from Charging Bay to the battery pack and distributes charge to handpiece.
- **Battery Pack Latch** – Secures the battery pack to the handpiece. Depress the battery latch to release the battery pack from the handpiece.

Battery Pack - Installation & Removal

Battery Pack Installation:

- Rotate trigger to the SAFE mode.
- Align the battery pack contacts on the top of the battery pack with the battery receptacle on the handpiece.
- Slide a battery pack into the battery receptacle until the battery latch snaps indicating the battery pack is secure.
- Rotate trigger to the RUN mode.
- Test the handpiece and battery pack by depressing the trigger.
- Rotate trigger to the SAFE mode when not in operation.

Battery Pack Removal:

- Rotate trigger to the SAFE mode.
- Press down on the battery pack latch and slide battery pack out of the handpiece.
- Always remove battery pack when not in use.

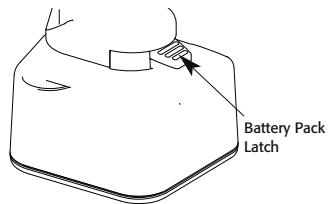
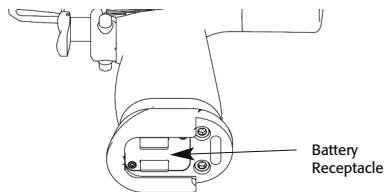
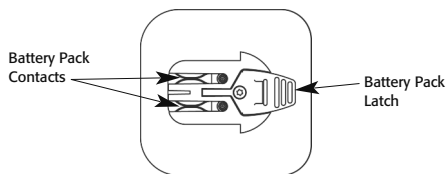

Troubleshooting

Symptom	Potential Cause	Solution
Battery pack will not connect properly to handpiece.	There is debris in the battery receptacle.	See cleaning recommendations.
	Battery pack contacts are damaged.	Replace battery pack.
	Battery pack latch is damaged.	Replace battery pack.
	Battery receptacle is damaged.	Send handpiece to Brasseler USA Medical, LLC, for service.
Battery pack malfunctions.	Over sterilization of battery pack.	Replace battery pack.
	End of life cycle for battery pack.	Replace battery pack.
	Subjected to a dry cycle.	Replace battery pack.
	4-Bay Power Unit fuses are open/blown.	Replace with appropriate rated fuses. See 4-Bay Power Unit instructions for use.
Battery pack cannot be removed from handpiece.	Battery pack latch is damaged.	Send handpiece and battery pack to Brasseler USA Medical, LLC, for service.
	Battery receptacle is damaged.	Send handpiece and battery pack to Brasseler USA Medical, LLC, for service.
Battery pack is fully charged but won't run.	Battery pack malfunctioned.	Replace battery pack.
	Handpiece malfunctioned.	Send handpiece to Brasseler USA Medical, LLC, for service.

Cleaning Recommendations

Warnings:

- Clean, charge and sterilize battery packs before every use.

Cautions:

- Follow universal precautions for protective apparel when handling and cleaning contaminated battery packs.
- Remove battery pack from contaminated handpiece prior to cleaning and sterilization.
- DO NOT immerse a battery pack in any liquid. Contact corrosion may occur resulting in decreased performance of the battery pack and/or handpiece.
- Do not clean battery packs in an automated disinfecting washer or an ultrasonic cleaner.
- DO NOT use disinfectants with pH levels higher than 10.5. Higher concentrations greater than 10.5 may cause cracks in the housing material.
- DO NOT clean the battery pack contacts with abrasives.
- Dry battery packs before charging to avoid damage to the battery packs and charger.

Cleaning Procedures:

1. Remove battery pack from the handpiece.
2. Inspect the battery pack case for cracks. Remove damaged battery pack from service.
3. Wipe the battery pack case clean using a clean lint-free soft cloth lightly dampened with a hospital grade enzymatic disinfectant having a pH range of 6.5 to 10.5.
4. Rinse the battery pack thoroughly under running tap water.
5. Dry the battery pack with a clean lint-free soft cloth.
6. Clean battery pack contacts using a cotton swab lightly with isopropyl alcohol. DO NOT clean the battery pack contacts with abrasives.
7. Ensure battery pack and battery pack contacts are completely dry before charging or using battery pack.
8. Fully charge battery pack.
9. Sterilize as directed. See Sterilization Recommendations section.

Sterilization Recommendations

Steam sterilization has been found to be both safe and effective for the sterilization of BSPMAX™ II Large Bone Power System battery packs. The battery packs are capable of withstanding the recommended exposure times and temperatures of steam sterilization.

Warning:

- The use of disinfecting solutions for an exterior instrument wipe will not sterilize equipment.

Cautions:

- DO NOT sterilize battery packs with Ethylene Oxide (ETO).
- DO NOT sterilize battery packs in cold sterilization like CIDEX®.
- DO NOT “Peel Pack” battery packs for sterilization. Sterilization in a sealed pouch traps moisture which can cause damage.
- DO NOT sterilize battery pack while connected to the handpiece.
- DO NOT sterilize a battery pack if damage (cracks in the case) is apparent.
- DO NOT leave battery packs in a hot sterilizer for more than the prescribed time as shortened battery life will result.
- After sterilization, always allow battery packs to cool for at least one hour before use. Failure to comply may result in damage and a shortened battery pack life.
- Charging of battery packs should be completed prior to sterilization.

Sterilization Recommendations (continued)

Notes:

- These processes have been validated as being capable of cleaning and sterilizing BSPMAX™ II battery packs.
- The sterilizer manufacturer's written instruction for cycle parameters, load configuration and AAMI guidelines for steam sterilization should be followed.

Parameters for Steam Sterilization of BSPMAX™ II Battery Packs

Steam Sterilization	Minimum Temperature	Minimum Exposure Time	Dry Time
Pre Vacuum (Wrapped)	270° F (132° C)	3 Minutes	No Dry Time
Steam Gravity*	270° F (132° C)	3 Minutes	No Dry Time

*Unwrapped only

Other Sterilization Option

BSPMAX™ II battery packs have been validated for sterilization in a STERRAD® gas plasma system. Sterilize per STERRAD® user instructions.

Note: After minimum sterilization exposure time immediately remove battery pack. Allow to air dry and cool for at least one hour before use.

Specifications

9.6V Battery Pack PM-X00-710

12V Battery Pack PM-X00-715

Weight	1.0lb (.45kg)	1.45lb (.66kg)
Voltage	9.6Vdc	12Vdc
Charging Time	5-60 Minutes	5-60 Minutes
Run Time Fully Charged	3-10 Minutes	3-15 Minutes
Working Temperature	32°F - 122°F (0°C - 50°C)	32°F - 122°F (0°C - 50°C)
Type	Nickel Cadmium (Ni-Cd)	Nickel Cadmium (Ni-Cd)

Environmental Requirements

Operating:



- Ambient temperature : 50°F to 70°F (10°C to 21°C)
- Relative Humidity 30% - 75%
- Atmospheric Pressure: 700hPa to 1060hPa

Transport :



- Ambient temperature : -4°F to 158°F (-20°C to 70°C)
- Relative Humidity 10% - 100%
- Atmospheric Pressure: 500hPa to 1060hPa

Warranty

Brasseler USA® Surgical Power & Accessories warrants all BSPMAX™ II Handpieces, Attachments and Accessories excluding Battery Packs to be free from defects in material and workmanship for a period of one (1) year from the invoice date. Battery Packs are warranted to be free from defects in material and workmanship for a period of ninety (90) days from the invoice date. The warranty is limited to the repair of the product without charge. This warranty is nontransferable. In addition, this warranty is void in the event of any of the following: abuse, misuse, neglect or use in other than normal surgery environment, disassembly, alteration or unauthorized repair, or in the event that the product has not been used in reasonable manner and in compliance with the written instructions provided by Brasseler USA® Surgical Power & Accessories.

Return Goods Policy

If product needs to be returned, the following applies:

Consumable/Disposable Product:

Any unused consumable/disposable product may be returned for credit within ninety (90) days of invoice date if it qualifies for resale (unopened and unmarked package). Products may be subject to a restocking fee. Credit will not be issued for products that do not qualify for resale.

Capital Equipment:

Any unused capital equipment may be returned for credit within thirty (30) days of invoice date if it qualifies for resale (unopened and unmarked package). Products may be subject to a restocking fee. Credit will not be issued for products that do not qualify for resale.

Packaging and Shipping:

Returned items should be packaged in original packaging. Credit will not be issued for items damaged in return shipment due to packaging inadequacy.

Note: It is unlawful to ship contaminated non-sterilized products.

Contact a Customer Service Representative at Brasseler USA® Surgical Power & Accessories at 800-535-6638 to obtain a "Return Merchandise Authorization" (RMA) number.

Please include the following information with the returned product(s):

- Catalog number, serial number and lot number (if applicable) of device.
- Return Merchandise Authorization (RMA) number noted with the return.
- Original invoice number or copy of original invoice.
- Original invoice date.
- Customer name, address and account number.
- Itemized packing list.
- Brief statement describing reason for product return.

Return to:

***Brasseler U.S.A. Medical, LLC
4837 McGrath Street
Ventura, CA 93003***

Product Disposal

Dispose of product or recycle in accordance with local laws and regulations.

Product Ordering Information

HANDPIECES

PM-X08-700	MODULAR DRILL/REAMER
PM-X12-700	SAGITTAL/OSCILLATOR SAW
PM-X14-700	RECIPROCATOR/STERNUM SAW

ATTACHMENTS - DRIVERS

PM-X08-701	PIN DRIVER
PM-X08-702	WIRE DRIVER

ATTACHMENTS - DRILLS

PM-X08-905	TRINKLE/AO®
PM-X08-910	1/4 IN JACOBS® CHUCK W/ KEY
PM-X08-915	5/32 IN JACOBS® CHUCK W/ KEY
PM-X08-920	HUDSON®
PM-X08-925	ZIMMER®
PM-X08-930	1/4 IN KEYLESS CHUCK
PM-X08-935	3 MM KEYLESS CHUCK
PM-X08-940	ZHS - ZIMMER®/HUDSON®/STRYKER® UNIVERSAL

ATTACHMENTS - REAMERS

PM-X08-911	1/4 IN JACOBS® HI TORQUE W/ KEY - EXTENDED LENGTH
PM-X08-950	HUDSON® - EXTENDED LENGTH
PM-X08-955	ZIMMER® - EXTENDED LENGTH
PM-X08-960	AO® - EXTENDED LENGTH
PM-X08-965	ZHS - ZIMMER®/HUDSON®/STRYKER® UNIVERSAL - STANDARD LENGTH
PM-X08-970	1/4 IN JACOBS® HI TORQUE W/ KEY - STANDARD LENGTH

ATTACHMENT - STERNUM SAW GUARD

PM-X14-901	STERNUM SAW GUARD
------------	-------------------

ACCESSORIES

PM-X00-520	4-BAY POWER UNIT 110V
PM-X00-521	CHARGING BAY COVER
PM-X00-522	4 BAY POWER UNIT 230V
PM-X00-710	9.6V BATTERY PACK
PM-X00-715	12V BATTERY PACK
PM-X00-731	STANDARD BATTERY PACK CHARGING BAY
PM-X00-770	STERILIZATION CASE – 3 HANDPIECES
PM-X08-000	1/4 IN JACOBS® CHUCK KEY
PM-X08-001	5/32 IN JACOBS® CHUCK KEY

BRASSELLER USA® SURGICAL POWER & ACCESSORIES OFFERS A COMPLETE LINE OF CUTTING ACCESSORIES (SAW BLADES/RASPS, BURS, K-WIRES, STEINMANN PINS, TWIST DRILLS AND ORTHOPAEDIC PIN PACKS).



Brasseler U.S.A. Medical, LLC
One Brasseler Boulevard • Savannah, GA 31419
800-535-6638 • 912-921-7578 (fax)
BrasselerUSAMedical.com

Brasseler U.S.A. Medical, LLC, has implemented a quality management system that is certified under ISO 13485:2003. AO[®] is a registered trademark of AO Technology AG. CIDEX[®] and STERRAD[®] are registered trademarks of Advanced Sterilization Products[®], Division of Ethicon, Inc., a Johnson & Johnson Company. Hudson[®] is a registered trademark of Hudson Industries, Inc. Jacobs[®] is a registered trademark of Jacobs Chuck Manufacturing Company. Stryker[®] is a registered trademark of Stryker Corporation. Zimmer[®] is a registered trademark of Zimmer, Inc. Brasseler U.S.A. Medical, LLC, is not affiliated with any of the above and makes no claim to copyrights or trademarks which are the property of these companies. Brasseler USA[®] and BSPMAX[™] are trademarks of Peter Brasseler Holdings, LLC, or its affiliates. All other trademarks are trademarks of their respective owners or holders. Colors, specifications and product availability subject to change. Brasseler USA[®] Surgical Power & Accessories products are sold by Brasseler U.S.A. Medical, LLC, One Brasseler Boulevard, Savannah, Georgia 31419, United States.